

Product chapter

AXRY-EX

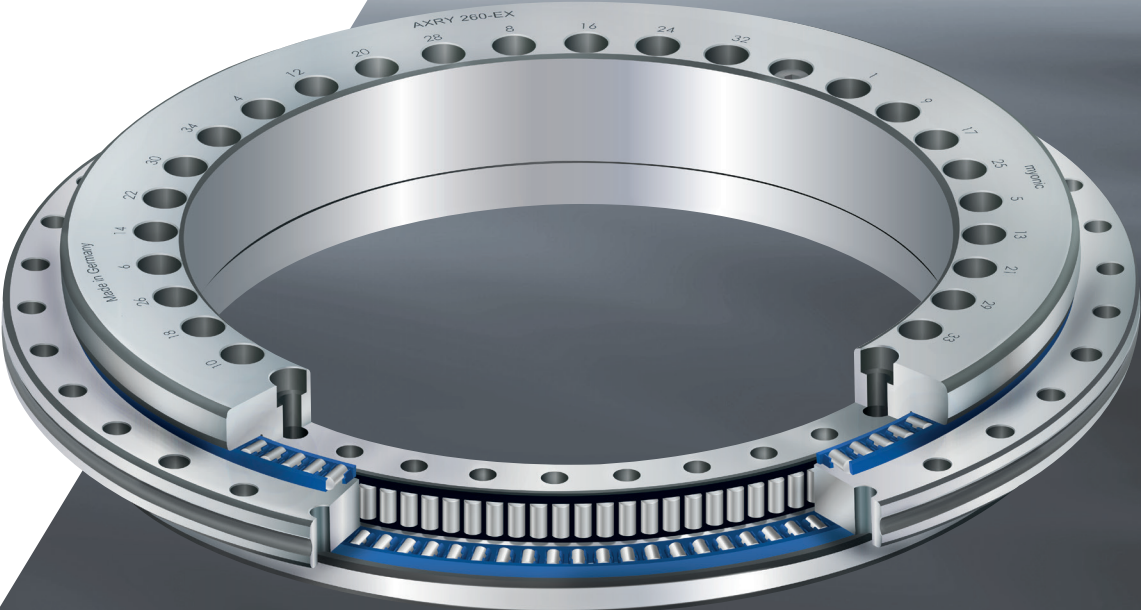

General

General AXRY-EX bearings are double direction, screw-on precision bearing units ready for installation and intended for highly-rigid applications, for example for rotary tables or milling heads. The bearing absorbs axial and radial forces as well as tilting moments backlash-free.

AXRY-EX bearings are suitable for grease and oil lubrication, and are designed for maximum rigidity. The friction torques of the bearing have been optimised, and the starting torque and running torque are almost identical.

In this way, myonic-AXRY-EX bearings fulfil all the requirements for modern highly-dynamic and direct-driven machine axes.

For high speed applications, we recommend the AXRY-NGS designs.

Accuracy/designs AXRY-EX bearings are supplied in the standard series with dimension tolerances P5 acc. DIN 620. The running tolerances (axial and radial runout) are available in 2 classes, normal and constricted.

For the EX bearings, all variations, such as limitation of the axial and radial runout, height tolerances H1/H2 and the design with supported L-section ring AC are available without limitations.

The inner ring and the axial washer have the same axial runout properties.

Measuring system AXRY-EX bearings can be equipped with inductive angle measurement systems. These are available in incremental and absolute design (as single or multi-head systems in very different accuracies).

Mounting this system onto the bearing facilitates maximum accuracies through the exploitation of the precision on the bearing ring with minimal concentricity errors to the shaft (table).

See more in the chapter Measuring systems.

Specific bearing features

- Bearing structure** AXRY-EX bearings consist of three rings:
- Inner ring
 - Outer ring
 - Axial washer
- The hole inner ring features an appropriate fit. The axial washer is unsupported in the area of the hole.
- Two axial roller sets and one radial roller set absorb radial and axial forces and tilting moments. All AXRY roller sets are radially and axially equipped with high-performance cages.
- Fastening screws** The completely assembled bearing is held together with fastening screws which are not usually removed. However, if the fastening screws are removed, they may not be removed until after the bearing has been completely screwed on and must be replaced with normal screws. Incorrect removal of the fastening screws can cause a decline in the axial/radial runout or the repeatability.
- Lubrication** The bearing is first filled with a special grease (without suffix, Li-special soap with a mix of synthetic hydrocarbon oil and mineral oil). The grease is a special easy-running grease with appropriate additives for the operation of preloaded roller bearings.
- Most commercially-available greases are not suitable for the operation of axial-radial bearings and generate too much friction in the bearing. For details see general chapter.
- Run-in cycle** The run-in cycles during initial operation and after relubrication should in particular be observed. Overfilling of the bearing is to be avoided, as excessively high grease quantities generate higher friction heat levels and increasing running torques with faster speeds.
- If the swivel axes run slowly, the run-in cycle no longer has to be conducted.
- Relubrication** Relubrication takes place radially via lubrication channels in the outer ring or optionally via the inner ring. myonic application engineering is happy to assist with further details on relubrication quantities or cycles.
- The bearings are only provided with preservation for oil-lubricated applications (suffix L-120).
- Preservatives** The used corrosion protection oil is compatible und mixable with most of greases and oils produced on a mineral basis.
- Check for compatibility when using synthetic lubricants and other consistency enhancers than lithium (complex) soaps.
- In case of incompatibility, please consult myonic as to further procedures.

Specific bearing features

Height tolerances H1 and H2

Both height dimensions, seen from the normal axial contact area of the outer ring, can be substantially limited.

H1 refers to the position of the table in order for example to minimally adjust the labyrinth seal gap against the penetration of coolant from the machining area.

H2 refers to the adjacent construction under the bearing, for example for adjusting the clearance of a worm gear drive. The exact tolerances are located in the product tables.

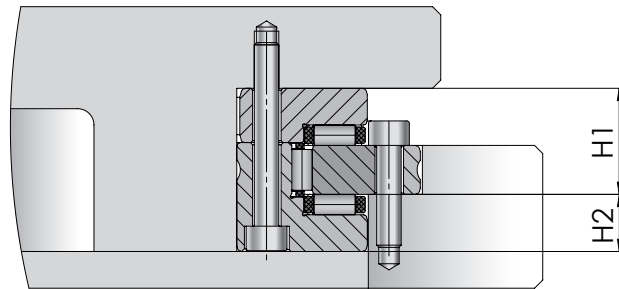

Supported L-section ring AC

AXRY-EX bearings can be exposed or installed with whole surface support. If the L-section ring is supported across its whole surface by a support ring, the tilting rigidity of the bearing increases by approx. 15 to 20 %.

In order to prevent an increase in the bearing friction torque, the bearing preload is adapted (suffix AC). If normally-aligned bearings with supported L-section rings are used, the bearing friction torque increases by 10 – 20 %, and in part more. For further details, see bearing rigidity

Customer-specific design Jxxxx (J-number)

myonic produces customer-specific designs which are designated with J and a number.

Such J-numbers can, for example, include:

- Specific, application-related preload values
- Special directives for marking or packaging
- Special lubrication systems
- Changed dimensions/tolerances
- Outer ring rotation design

Specific bearing features

Limiting speeds/temperatures/friction

The limiting speed n_G stated in the dimensions table can be achieved for the selected axial-radial bearing in swivel operation or during short-term continuous operation.

In case of prolonged operation in the area of the limiting speed, the bearing increasingly heats up.

For high speed applications such as milling/turning tables, we recommend bearings in the AXRY-NGS design.

Axial-radial bearings in the AXRY-EX series are equipped with cages both in the radial and in the axial part. In this way, the bearings run under full preload with very little friction. Here the starting friction torque is only slightly higher than the friction torque M_{RL} at 5 rpm, which is listed in the product chapter.

Therefore, AXRY-EX bearings are especially suitable for highly-dynamic, direct-driven, multi-axis applications.

The friction torque of the bearing is amongst other things also influenced through the viscosity and the quantity of the lubricant. The myonic standard grease can be used prealigned within a wide area of application.

Excessively high lubrication quantities substantially increase the bearing friction. Excessively low viscosities can lead to mixed friction.

myonic cages are designed to absorb as high a quantity of lubricant as possible to emit the lubricant during operation over a prolonged time period directly onto the rollers.

Please adhere to the appropriate run-in cycles during run-in or relubrication. The specifications for the adjacent construction and surrounding parts are to be adhered to!

Nominal life time

Nominal life time

The calculation of the nominal life time takes place via special calculation programs.

For this purpose, you are welcome to request our technical questionnaire. Our application engineering colleagues are then happy to execute the calculation itself for you.

Calculations at myonic

The following is required for calculation:

- Details on application (drawings, sketches, specifications)
- Workpiece dimensions and weight
- Details on the load cycle
(cutting forces, speeds, operating durations)

Static load safety factor

The calculation of the static load safety factor must be executed separately for the radial and axial bearing parts. For the machine tool application, the static load safety factor should total $S_o > 4$, in order to avoid lasting plastic deformations in the bearing.

$$S_o = \frac{C_{or}}{F_{or}} \quad \text{or} \quad S_o = \frac{C_{oa}}{F_{oa}}$$

S_o = Static load safety factor

C_{oa}/C_{or} [N] = Static load rating acc. dimensions table

F_{or}, F_{oa} [N] = Static load of radial or axial bearing part

Static limiting load diagrams

Static limiting load diagrams

The static limiting load diagrams serve to:

- Check the selected bearing size under mainly static load
- Determine the tilting moment M_k which the AXRY is able to absorb in addition to the axial load

The static limiting load diagrams take into account for the roller element set the static load safety factor $S_o \geq 4$ and the screw and bearing ring strength.

Example:

Static limiting load diagram for AXRY

- 1 Bearing/size
 - 2 Permitted range
 - 3 Unpermitted range
- M_k Maximum tilting moment in [kNm]
 F_a Axial load in [kN]

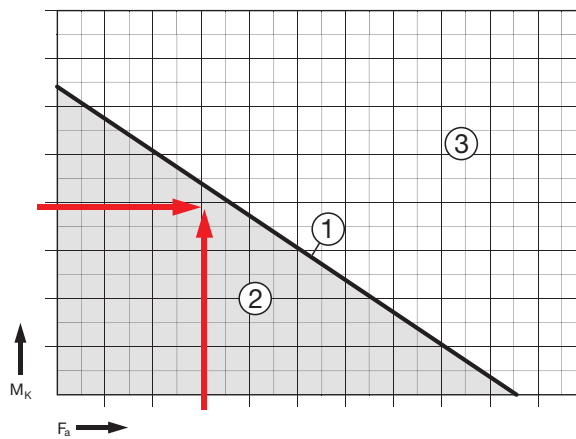

Static limiting load diagrams

Limiting load diagram axial-radial bearings
AXRY 50-EX bis AXRY 80-EX

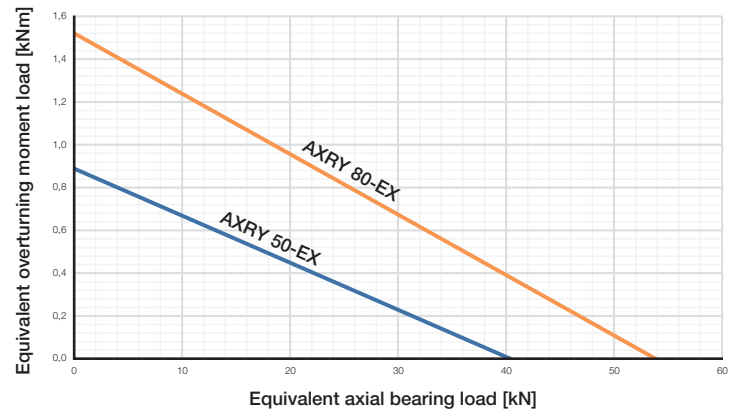

Limiting load diagram axial-radial bearings
AXRY 100-EX bis AXRY 150-EX

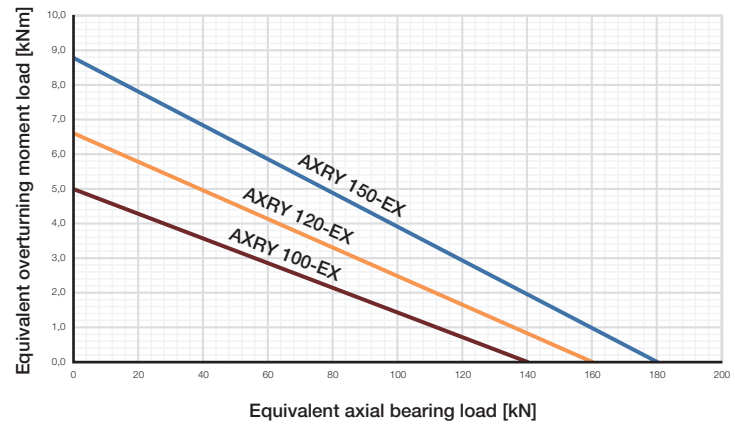

Design of the adjacent construction

In the following sketches and tables, the design of the adjacent construction is described.

Pay particular attention to the connection surfaces, as any deviations will have an effect on the overall accuracy of the roller bearing.

In order to avoid a decline in bearing friction torque, accuracy requirements and running characteristics, the recommended tolerances may not be exceeded.

Press fits In principle, when the fit is too constricted, the radial bearing preload increases, and thus...

...the following increases:

- The surface pressure in the raceway
- The bearing friction
- The bearing heat
- The amount of wear

...the following is reduced:

- The maximum speed
- The life time

Clearance fit If the rotating ring is not supported by interference fits, displacement of the rotation axis raceway to table centre is probable. The clearance from the fit table to bearing bore (also applies for the clearance bearing outer diameter to table with rotating outer ring) can add to the radial runout.

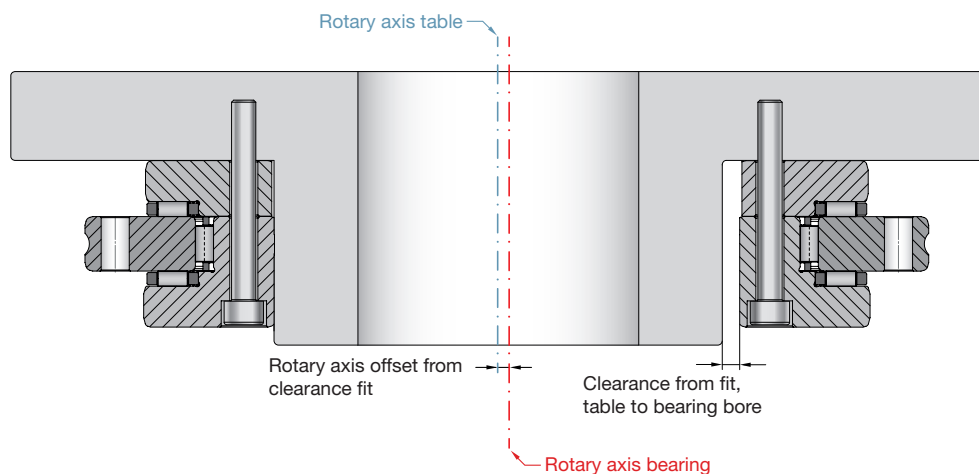

Design of the adjacent construction

No support or insufficient support of the inner ring leads to un-defined operating conditions such as vibrations, radial runout errors and repeatability etc.

In order to achieve the rigidities offered in the product chapter, the following table dimensions must be adhered to.

Recommended minimum wall thickness of the table:

AXRY	Minimum wall thickness [mm]	Max. passage [mm]
50	12	26
80	12.5	55
100	15	70
120	16	88
150	16	118

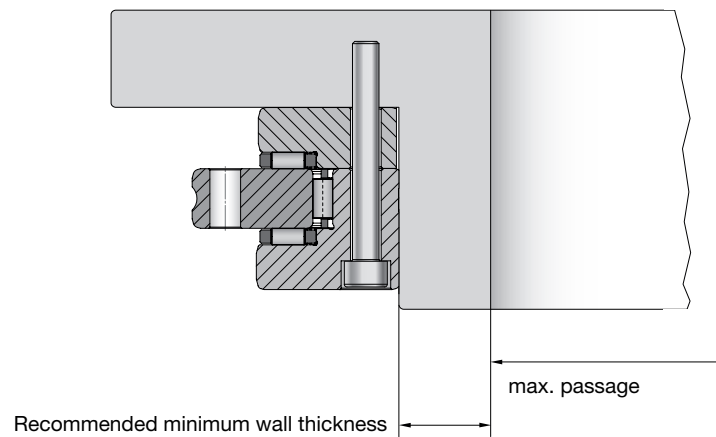

Recommended fits, shaft

General The accuracy of the fits and the geometrically-correct design of all adjacent parts have a direct effect on the accuracy requirements and the dynamic properties of the bearing and the table.
Please observe the construction notes in the general catalogue chapter.

Normal requirement On rotating and stationary shafts, the bearing inner ring is to be supported across its whole surface and the shaft is to be designed with a fit acc. h5.
In this way, the bore tolerance of the bearing generates a transition fit with a slight tendency to a clearance fit.

Higher requirement **Max. accuracy requirements:**
For the maximum accuracy requirement with rotating inner ring, a clearance fit 0 must be targeted; existing clearance fits can add to the radial runout.
The actual dimension of the bearing bore can be found in the inspection report enclosed with every bearing.

Higher dynamic properties:
In case of higher speeds ($ndm > 35,000$ mm/min) and prolonged operating durations (>10 %), do not exceed an interference fit of 5 μm .

Recommended fits, shaft

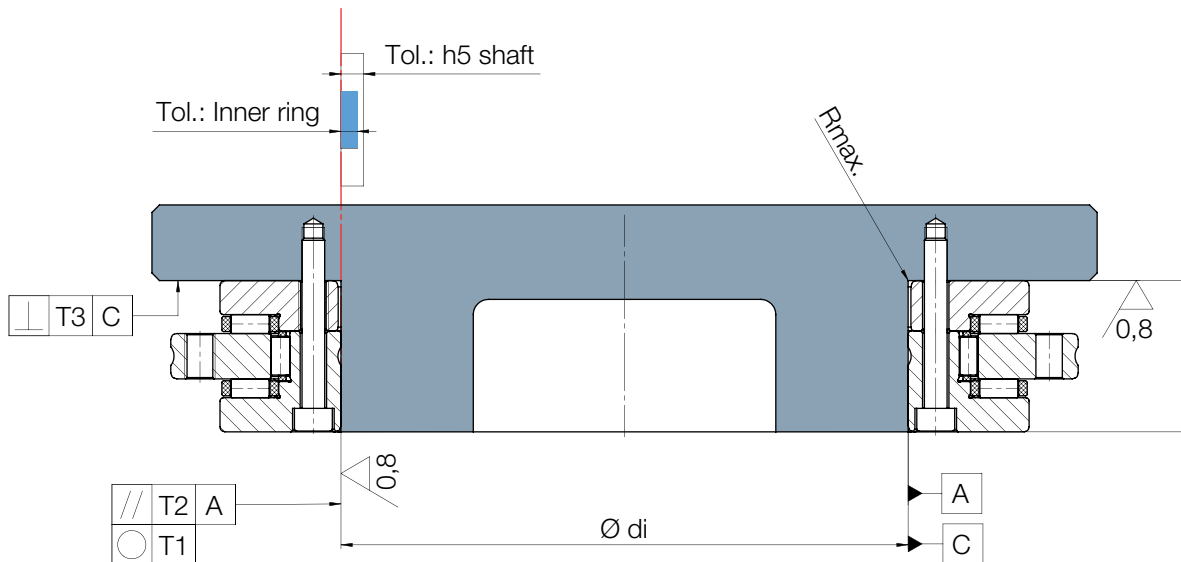

Axial/ radial bearing	Shaft \varnothing di [mm]	Tolerance zone Bearing inner \varnothing		Tolerance zone h5 of the shaft \varnothing		Roundness	Parallelism	Perpen- dicularity	Maximum corner radius
		d [mm]	-0.008	di [mm]	-0.011	T1	T2	T3	Rmax. [mm]
						[μ m]	[μ m]	[μ m]	
AXRY 50-EX	50	0	-0.008	0	-0.011	3	1.5	3	0.1
AXRY 80-EX	80	0	-0.009	0	-0.013	3	1.5	3	0.1
AXRY 100-EX	100	0	-0.010	0	-0.015	4	2	4	0.1
AXRY120-EX	120	0	-0.010	0	-0.015	4	2	4	0.1
AXRY150-EX	150	0	-0.013	0	-0.018	5	2.5	5	0.1

Recommended fits, housing

General The accuracy of the fits and the geometrically-correct design of all adjacent parts have a direct effect on the accuracy requirements and the dynamic properties of the bearing and the table.

Please observe the construction notes in the general catalogue chapter.

Outer ring stationary It is possible to do without a fit in the housing or alternatively to have a G7 fit design. Outer ring diameter clearance to the housing makes assembly easier.

In case of higher dynamic requirements on the rotating shaft, maintain a minimum clearance of 20 µm for the fit seat of the outer ring to the housing.

Outer ring rotates **Normal requirement:**
Design the rotating housing with a J6 clearance; here a transition fit results with a tendency for clearance fit. Design the fit seat across the entire height of the outer ring.

Max. accuracy requirement:
A clearance fit of 0 is to be targeted; existing clearance fits can add to radial runout. The actual dimension of the bearing outer diameter can be found in the inspection report enclosed with all bearings.

Higher dynamic properties:
In case of higher speeds ($ndm > 35,000$ mm/min) and prolonged operation durations, do not exceed an interference fit of 5 µm.

Recommended fits, housing

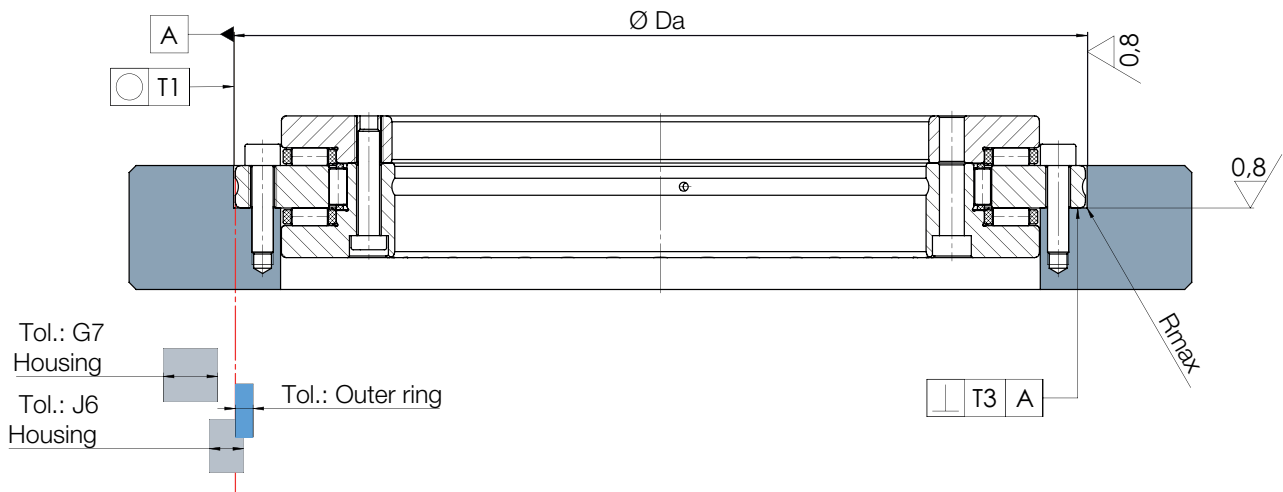

Axial/ radial bearing	Housing Ø Da [mm]	Tolerance zone Bearing outer Ø D [mm]		Stationary outer ring			Rotating outer ring				
				Tolerance zone G7 of the housing Ø		Round- ness, perpen- dicularity T1, T3 [µm]	Tolerance zone J6 of the housing Ø		Round- ness T1 [µm]	Perpen- dicularity T3 [µm]	Maximum corner radius Rmax. [mm]
				Da [mm]			Da [mm]				
AXRY 50-EX	126	0	-0.011	0.054	0.014	8	0.018	-0.007	5	5	0.1
AXRY 80-EX	146	0	-0.011	0.054	0.014	8	0.018	-0.007	5	5	0.1
AXRY 100-EX	185	0	-0.015	0.061	0.015	8	0.022	-0.007	7	7	0.1
AXRY120-EX	210	0	-0.015	0.061	0.015	10	0.022	-0.007	7	7	0.3
AXRY150-EX	240	0	-0.015	0.061	0.015	10	0.022	-0.007	7	7	0.3

Bearing rigidity

Supported L-section ring AXRY bearings can be installed exposed or supported across their whole surface. If the L-section ring (bearing inner ring) is supported across its whole surface by a support ring (e.g. worm gear), the tilting rigidity of the bearing increases by approx. 15 to 20 %.

Depending on the installation situation, different preload alignments in the bearing are required. For this reason, it is important only to order bearings with the suffix AC for bearing situations with a supported L-section ring. Design the support ring at least twice as high as the axial washer of the bearing.

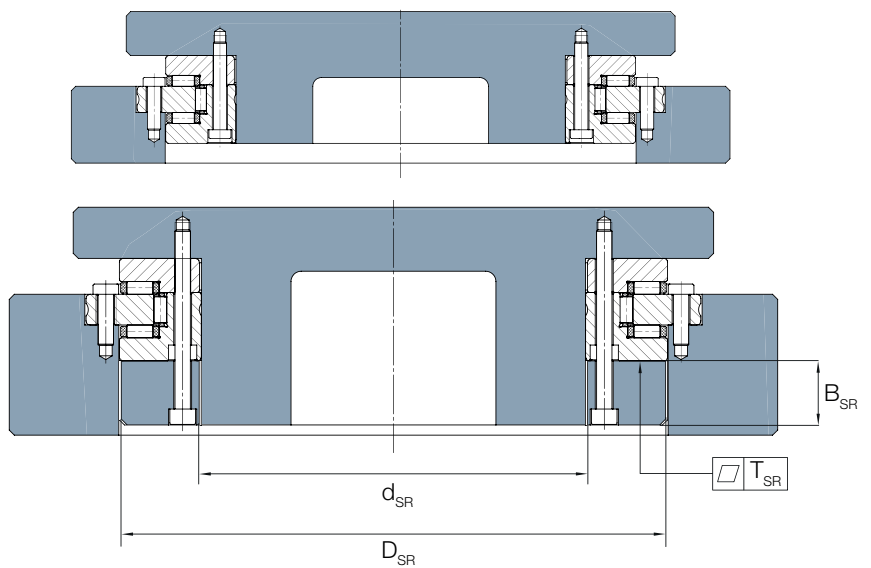

Recommendation: Support ring for maximum rigidity

Support ring for bearing size	Inner diameter	Outer diameter	Width	Evenness/contact area
	d_{SR} [mm]	D_{SR} max. [mm]	B_{SR} [mm]	T_{SR} [μ m]
AXRY 50-EX	51	105	12	3
AXRY 80-EX	81	130	15	3
AXRY 100-EX	101	161	16	4
AXRY 120-EX	121.5	185	18	4
AXRY 150-EX	151.5	214	18	5

Order designation

Designation system

Bearing

AXRY 150 - EX - 2Z - PRR50 - H1 - H2 - AC - JXXXX - L120

Construction series

Bore
in mm

Bearing type
EX = Standard

Seal:
Without = No seal
AZ = Axial washer, sealed
IZ = Inner ring, sealed
2Z = Sealed on 2 sides

Accuracy requirements:
Without = Standard accuracy requirement
PRR50 = Axial and radial runout tolerances restricted

Connection dimension H1:
Without = Standard tolerance
H1 = Restricted connection dimension H1

Connection dimension H2:
Without = Standard tolerance
H2 = Restricted connection dimension H2

Bearing preload:
Without = Standard alignment
AC = Alignment for supported L-section ring

Design:
Without = Catalogue design
JXXXX = Customer-specific design
(number is issued by myonic)

Lubrication:
Without = Standard grease
L120 = Bearing ungreased, only preserved
(e.g. for oil lubrication)
GXXX = Special grease
(number is issued by myonic)

For further technical details or special designs, please contact myonic application engineering.

Dimensions table AXRY-EX (standard design)

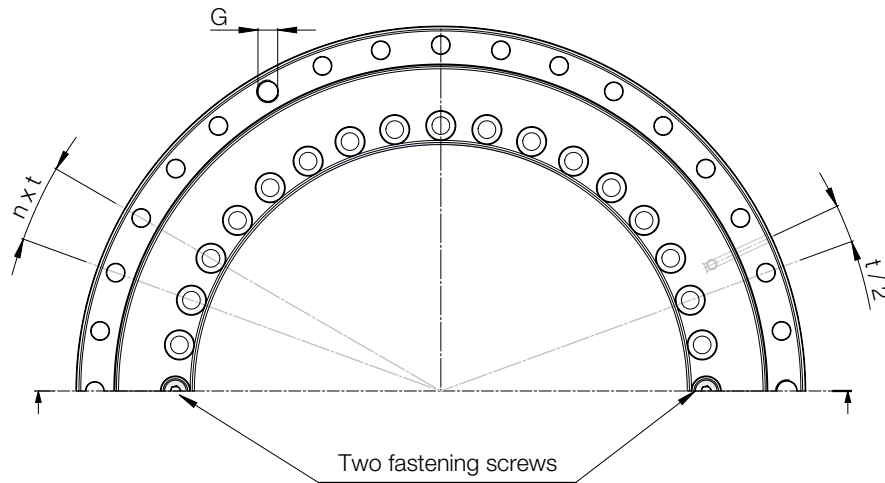
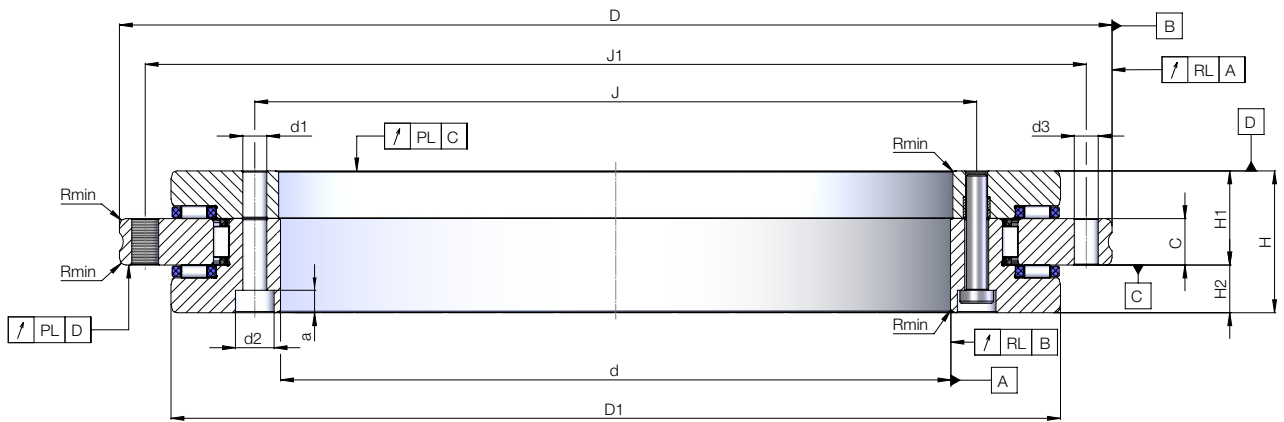

Designation	Weight	Dimensions [mm]													
		d	Δd	D	ΔD	H	H1	$\Delta H1$	$\Delta H1$	H2	$\Delta H2$	C	D1	J	J1
	m														
	[kg]								Restricted	Restricted		max			
AXRY 50-EX	1.6	50	-0.008	126	-0.011	30	20	± 0.125	± 0.025	10	± 0.02	10	105	63	116
AXRY 80-EX⁴⁾	2.4	80	-0.009	146	-0.011	35	23.35	± 0.150	± 0.025	11.65	± 0.02	12	130	92	138
AXRY 100-EX⁴⁾	4.1	100	-0.010	185	-0.015	38	25	± 0.175	± 0.025	13	± 0.02	12	161	112	170
AXRY 120-EX	5.3	120	-0.010	210	-0.015	40	26	± 0.175	± 0.025	14	± 0.02	12	185	135	195
AXRY 150-EX	6.2	150	-0.013	240	-0.015	40	26	± 0.175	± 0.03	14	± 0.02	12	214	165	225

4)

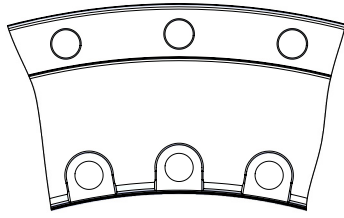
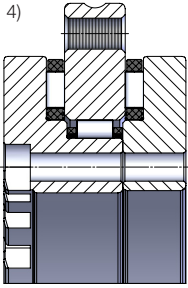

- 1) Including fastening screws or extraction thread.
- 2) Tightening torque for screws acc. DIN 912, strength class 10.9.
- 3) Attention! For fixing holes in the adjacent construction. Observe the pitch of the bearing bores.
- 4) Screw counterbores in large L-ring open to bearing bore. Bearing inside diameter is not supported in this area.
- 5) Please enquire in case of high speed applications.
- 6) Frictional torques as a reference value: measuring speed $n_{const} = 5 \text{ min}^{-1}$; with myonic standard grease; with myonic standard amount of grease; without support ring; Frictional torque can increase 2.5 times up to the limiting speed.
- 7) Measured on installed bearing with ideal adjacent construct.

Designation	Fixing holes									
	Inner ring				Outer ring				Number x Pitch	Screw tightening torque
	d1	d2	a	Number ³⁾	d3	Number ³⁾	Extraction thread			
							G	Number	nxt ¹⁾	M _A ²⁾ [Nm]
AXRY 50-EX	5.6	-	-	12	5.6	12	M5	2	12 x 30°	8.5
AXRY 80-EX ⁴⁾	5.6	10	4.4	12	4.6	12	M5	2	12 x 30°	8.5/4.5
AXRY 100-EX ⁴⁾	5.6	10	5.4	16	5.6	15	M6	3	18 x 20°	8.5
AXRY 120-EX	7	11	6.4	22	7	21	M8	3	24 x 15°	14
AXRY 150-EX	7	11	6.4	34	7	33	M8	3	36 x 10°	14

Designation	Load ratings				Limiting speed	Bearing friction torque ⁶⁾	Axial runout & radial runout ⁷⁾		Rigidity of the bearing position			Min. corner radius
	Axial		Radial				Grease	Grease	Standard	Restricted	Axial	
	dyn. C _a [kN]	stat. C _{0a} [kN]	dyn. C _r [kN]	stat. C _{0r} [kN]	n _G [rpm]	M _{RL} [Nm]	PL & RL [μm]	PL & RL [μm]	C _{al} [kN/μm]	C _{rl} [kN/μm]	C _{kl} [kNm/mrad]	R _{min} [mm]
AXRY 50-EX	33.5	161.6	22.7	39.2	2000	1.5	2	1	2.4	1.2	2.5	0.6
AXRY 80-EX ⁴⁾	39.5	215.4	51	104.9	1500	2.0	3	1.5	3	1.9	4.9	0.6
AXRY 100-EX ⁴⁾	89.2	560.6	56.3	126.9	1300	2.0	3	1.5	4.1	2.4	10	0.8
AXRY 120-EX	95.3	640.6	62.1	152.9	1150	4.5	3	1.5	4.8	3	16.3	0.8
AXRY 150-EX	100.4	720.7	68.4	185	1000	7.0	3	1.5	5.4	3.7	25.1	0.8